



SF-7085

B. E. - III (Sem. VI) (EC / ECC) Examination

May / June - 2011

EC-603 EC/ECC : Analog Integrated Circuit

Time : 3 Hours]

[Total Marks : 100

Instructions :

(1)

नीचे दृष्टावेक निशानीवाणी विगतो उत्तरवही पर अवश्य कभवी.
Fillup strictly the details of signs on your answer book.

Name of the Examination :
B. E. - 3 (SEM. 6) (EC / ECC)

Name of the Subject :
EC-603 EC/ECC : ANALOG INTEGRATED CIRCUIT

Subject Code No. : 7 0 8 5 Section No. (1, 2,.....) : NIL

Seat No. :

Student's Signature

- (2) Attempt all questions.
- (3) Figures to the right indicate full marks.
- (4) Assume data if required.

1 (i) Give answer in brief : 10

- (a) State the ideal characteristics of ideal op-amp.
- (b) Define :
 - (i) Input offset voltage and
 - (ii) Input offset current
- (c) Explain virtual ground concept.
- (d) If the op-amp in figure (1) is ideal, the o/p voltage V_{out} will be equal to

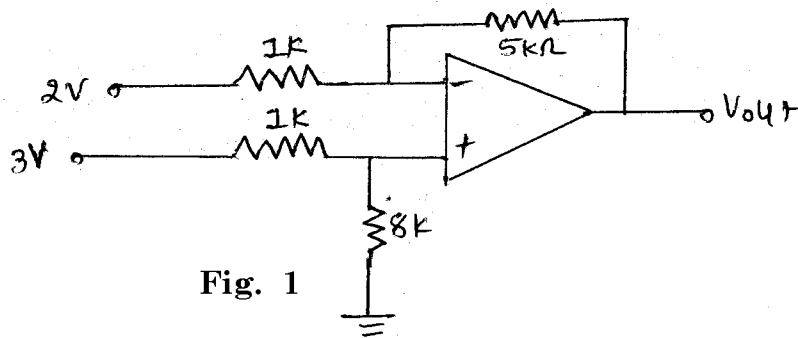

Fig. 1

(e) In the circuit of figure (2) V_o is :

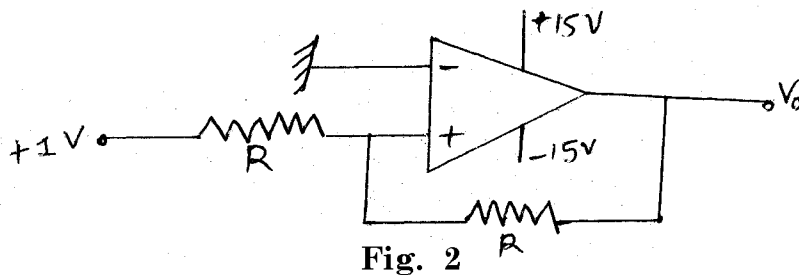

Fig. 2

- (ii) For the circuit in figure(3), specify the resistance value suitable for achieving gain of +2 when switch is open and -2 when switch is close. 5

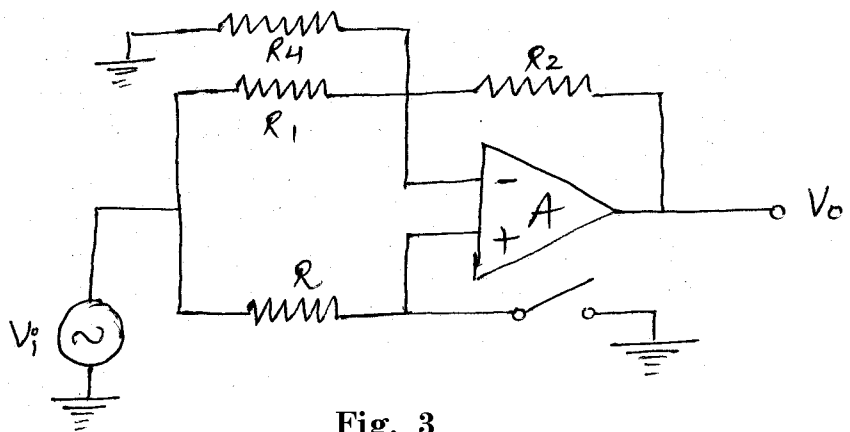

Fig. 3

- (iii) Explain sample and Hold circuit. 5

2 Attempt following questions :

- (i) Enlist the 4 differential amplifier configuration. Provide D.C. Analysis (operating point analysis) of any one. 6
- (ii) Explain Differential Amplifier with 3 op-amp. 6

OR

2 Attempt following questions :

- (i) Explain small signal half Wave Rectifier (HWR). 6
- (ii) For the non-inverting amplifier circuit, $R_F = 90 \text{ K}\Omega$. Find the voltage gain if
- (a) $A = \infty$
- (b) $A = 10^6$
- (c) $A = 10^5$.

3 Attempt any three :

18

- (i) Explain voltage shunt feedback Amplifier and derive the equation for closed loop voltage gain.
- (ii) For the instrumentation amplifier in figure (4), verify

$$\text{that } V_0 = \left(1 + \frac{R_2}{R_1} + \frac{2R_2}{R}\right) (V_2 - V_1).$$

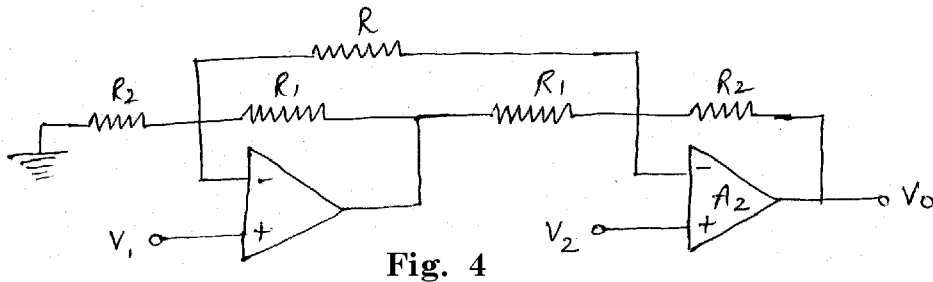

Fig. 4

- (iii) Calculate V_0 for the circuit in figure (5).

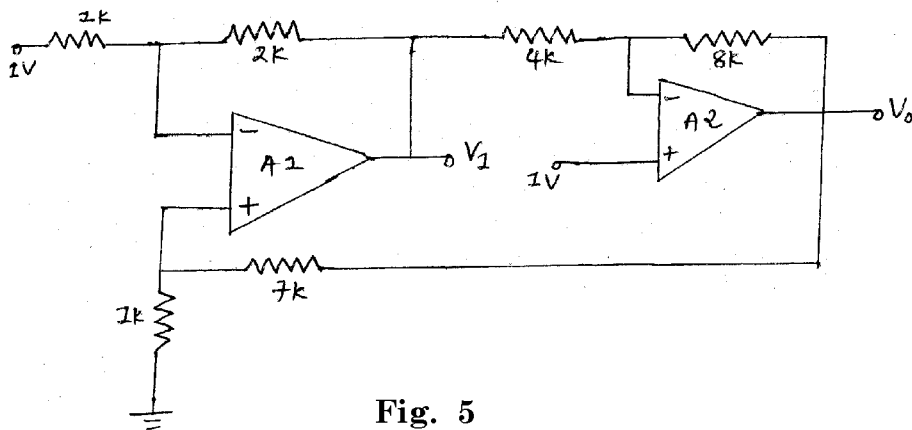

Fig. 5

- (iv) For the circuit in figure (6), show that

$$I_0 = \frac{V_i}{\left(\frac{R_1}{k}\right)}; k = 1 + \frac{R_2}{R_3}$$

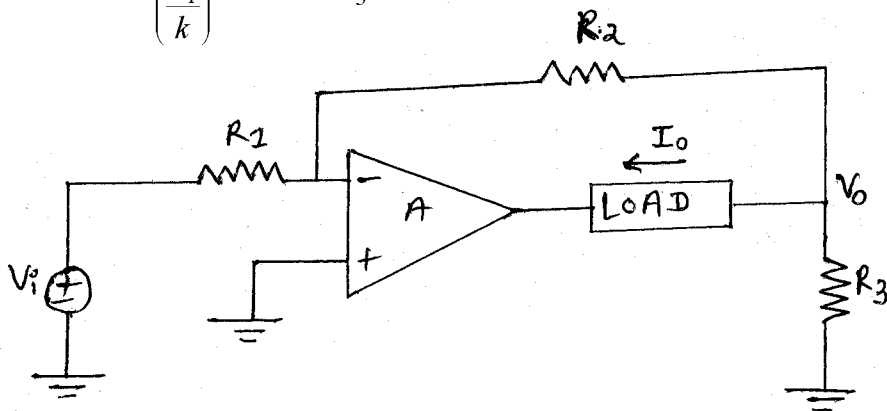

Fig. 6

- 4 (a) Answer the following questions : 10
- (i) Define resolution and conversion time.
 - (ii) State advantages of active filters over passive filters.
 - (iii) What is the function of decoupling capacitor in timer IC 555.
 - (iv) Classify A/d & D/A converters.
 - (v) What is the gain of second order filter ?
- (b) Derive the equation of cut off frequency for low pass filter. 5
- (c) Derive the condition required to design oscillator circuit. 5
- 5 Attempt any two : 14
- (a) Explain application of 555 timer IC as monostable multivibrator.
 - (b) Explain successive approximation type A to D converter.
 - (c) A $10 \mu\text{s}$ 555 monoshot is powered from $V_{CC} = 15 \text{ V}$. What voltage must be applied to the control input to stretch T_1 from $10 \mu\text{s}$ to $20 \mu\text{s}$?
- 6 Attempt any two : 16
- (a) Derive the equation for gain and frequency for second order butterworth high pass filter. Also draw the frequency response and locate cutoff frequency on it.
 - (b) Derive the frequency of oscillations for wein bridge oscillator. Also find the necessary condition for oscillators.
 - (c) Design a divide by 5 circuit to obtain 2 kHz square waveform from pulses of frequency 10 kHz. Use 555 timer.
-